

Thermal Protected Transient Suppression Diode

Mechanical trip type (TTVS)

TTVSxxM Series

Description



Thermally Protected Transient Voltage Suppression Diode (TTVS) is a transient suppression diode. Combined with TVS and thermal fuse (ATCO). When the transient energy far exceeds TVS its own endurance range, TVS burns out due to over-electrical stress, or the internal structure of the TVS changes due to long-term operation, and the electrical properties of the TVS degrades and the heat dissipation capacity is reduced to cause the junction temperature continues to increase and eventually the TVS is burned due to overheating. When an appeal situation occurs, the internal thermal protection of TTVS takes action and disconnects the TVS from the main circuit.

Thermally protected transient voltage suppression diodes (TTVS) are widely used in overvoltage protection of new energy equipment and communication equipment. It plays a big role in the absorption of surges and abnormal voltage.

SETsafe | SETfuse's thermally protected transient voltage suppression diode TTVSxxM series are mainly composed of transient voltage suppression diodes(TVS), thermal fuse (ATCO), potting material, flame-retardant case and metal accessories (pins). Nominal Discharge Current: 15kA; Maximum continuous operating voltage: (58 ~ 76) VDC, Certification: TUV, Complied with RoHS and REACH.

Schematics

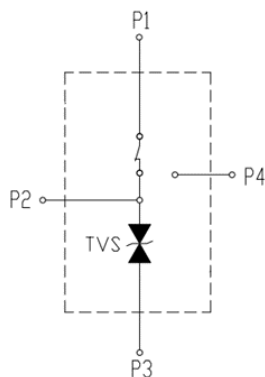

Structure

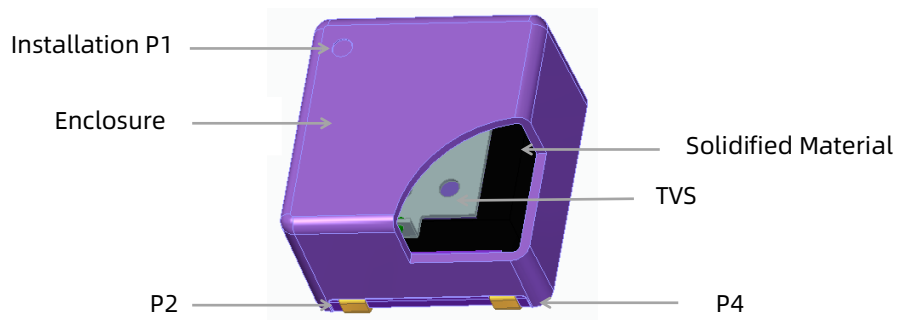

Thermal Protected Transient Suppression Diode
(Mechanical trip type)

Features

- High Reliability
- Small Size
- Failure Indication
- High Energy Capacity
- Sealing Material, Flame-retardant to V0 (UL 94)
- Comply with UL 1449 / IEC 61643-11

Applications

- Communication Equipment
- Security and Protection
- Industrial Control Equipment
- Communication Power Supply
- New Energy Equipment

Agency Information

Agency Symbol	Standards	The File No. and certification No. obtained by SETsafe SETfuse	Category
	EN 61643-11	J50556562	T2
环境	RoHS & REACH	符合	

Part Numbering System

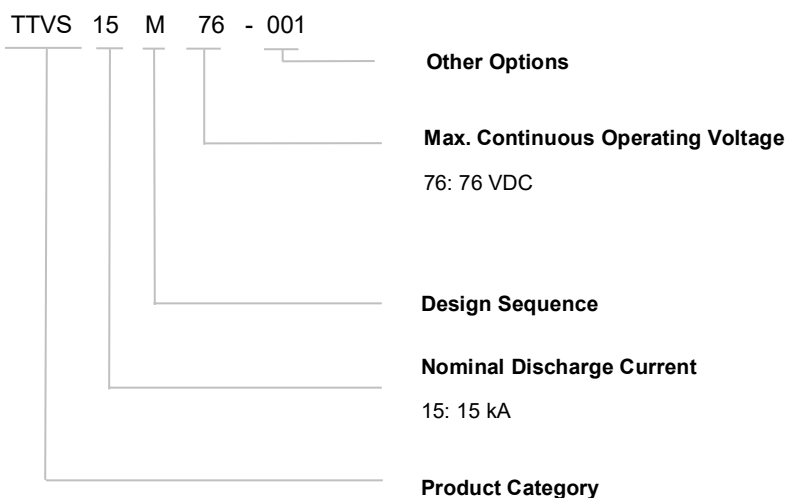

Note:

Part numbering system in the datasheet is only for selecting correct parameter and product features. Before placing order, please contact us for specifications and use the part number and product code in the specifications to place order to ensure the part is correct. Product code is the unique identification.

Thermal Protected Transient Suppression Diode
Mechanical trip type (TTVS)

TTVSxxM Series

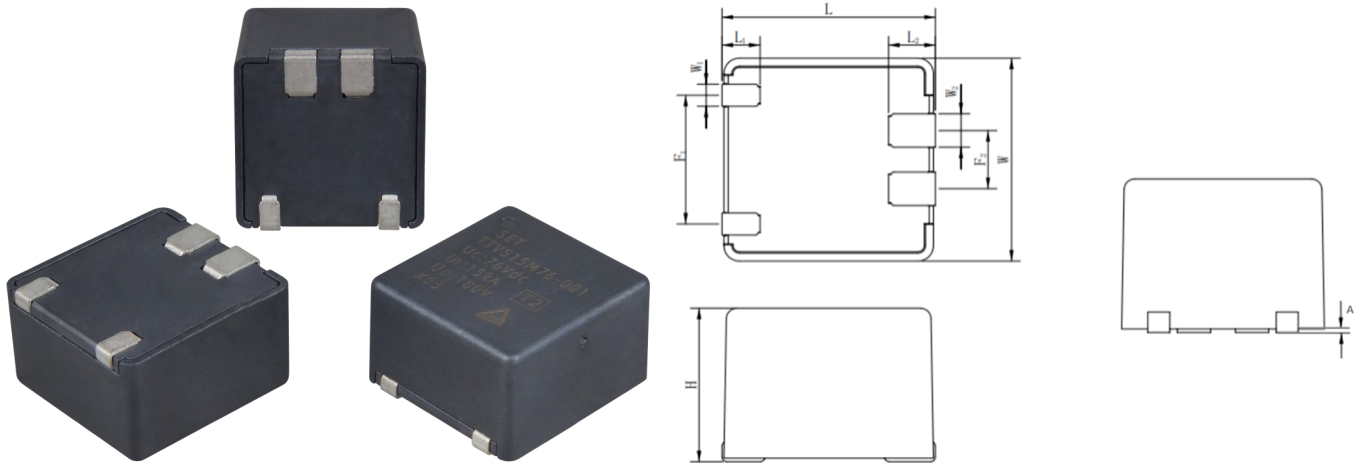

Note: Unit : mm

TTVS15M76

W	W ₁	W ₂	H	L
23.5 ± 0.8	2.5 ± 0.3	3.8 ± 0.3	14.0 ± 0.5	24.0 ± 0.5
L ₁	L ₂	F ₁	F ₂	A
4.3 ± 0.3	5.3 ± 0.3	14.6 ± 0.5	6.6 ± 0.5	0.4 ± 0.1

Specifications

Model	Dc Breakdown Voltage	Breakdown voltage Tests Current	Max. Continuous Operating Voltage	Nominal Discharge Current (8/20 μs)	Voltage Protection Level	Leakage Current	Static Capacitance	IEC/EN 61643-11
	V _{BR}	I _T	U _c	I _n	U _{P@I_n}	IR@VR	C@10KHz	
	V	mA	V	kA	V	μA	nF	Class II
TTVS15M58	67 ± 3	10	58	15	140	20	18	•
TTVS15M66	76 ± 4	10	66	15	160	20	15	•
TTVS15M76	90 ± 5	10	76	15	180	20	12	•
TTVS20M58	67 ± 3	10	58	20	140	15	18	•
TTVS20M66	76 ± 4	10	66	20	160	15	15	•
TTVS20M76	90 ± 5	10	76	20	180	15	12	•

Note:

The voltage protection level (Up) is selected according to the preferred value of IEC 61643-11:2011 6.4 according to the calculation results;

Voltage protection level preferred value (kV): 0.08, 0.09, 0.10, 0.12, 0.15, 0.22, 0.33, 0.4, 0.5, 0.6, 0.7, 0.8, 0.9, 1.0, 1.2, 1.5, 1.8, 2.0, 2.5, 3.0, 4.0, 5.0, 6.0, 8.0, 10;

Performance Curve for Reference

Breakdown Voltage-Temperature Curve

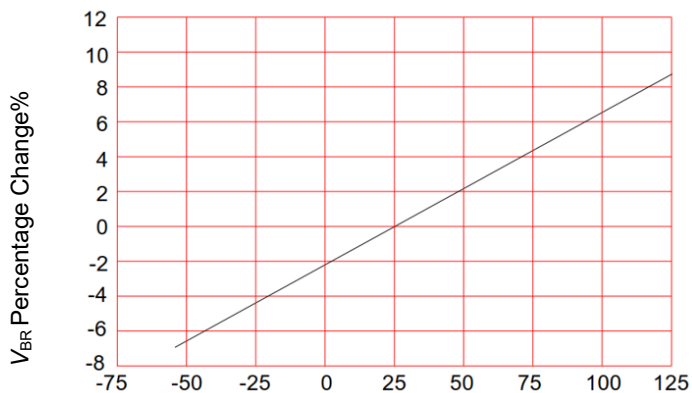

Junction Temperature(T_J)°C

Impulse Current-Temperature Curve

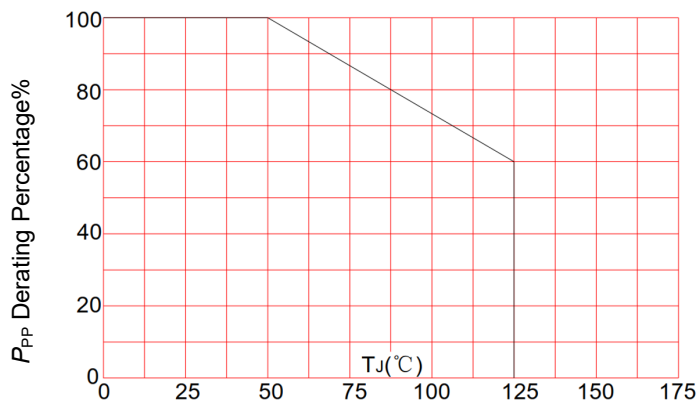

Junction Temperature(T_J)°C

Note: The default parameter of the product is 25 °C. If the parameter requirements of other ambient temperatures are considered, the design should consider the influence of temperature on the parameters.

Packaging Information

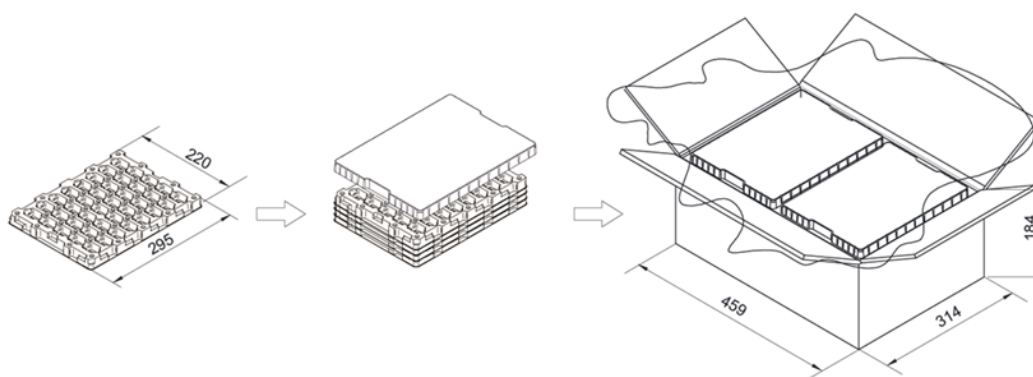

Unit: mm

Please contact us if you have special packaging requirements.

Item	Tray	Carton
Dimensions (mm)	295 × 220	455 × 314 × 195
Quantity (PCS)	40	640

Reflow Welding Parameters (Reference)

This product can meet reflow welding, reflow peak temperature should be less than 275 °C, 265°C above the temperature duration ≤40 s. Recommended Settings according to the following welding curve:

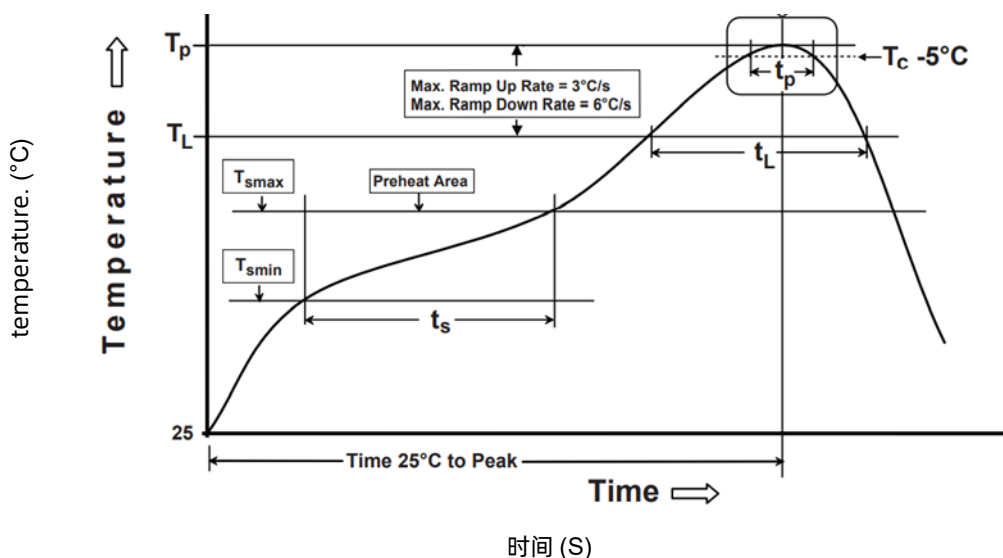

Item	Temp. (°C)	Time (s)
Preheating t_s	150 to 200	60 to 120
Dwelling t_L	230 to 275	120 (max)
Peak temperature t_p	265 to 275	40 (max)

Recommended Hand-Soldering Parameters

Item	Condition
Iron Temperature	350 °C (Max.)
Soldering Time	4 seconds (Max.)

Patents

Name	Region	Category	Patent NO.
A transient voltage suppressor of thermal protection type	China	Utility Model	ZL2021220841024
The utility model relates to a thermal protected transient suppression device	China	Utility Model	ZL2021231360206
Thermal protection varistor module and transient voltage suppressor	China	Appearance	ZL2021305707575
The utility model relates to a thermal protection transient voltage suppressor	China	Utility Model	ZL2021231355829
A novel transient voltage suppressor for overtemperature protection	China	Utility Model	ZL2022214731712

Glossary

Item	Description
V_{BR}	Breakdown Voltage The voltage of the transient suppression diode with the specified current I_T (test current) in the breakdown region. — (IEC 61643-321)
P_{PPM}	Rated Random Repeat Peak Pulse Power The maximum rating of the product of the rated random repeat peak pulse current (IPPM) and the specified maximum clamp voltage (VC). — (IEC 61643-321)
U_p	Voltage Protection Level Maximum voltage to be expected at the SPD terminals due to an impulse stress with defined voltage steepness and an impulse stress with a discharge current with given amplitude and waveshape. — (IEC 61643-11)
U_c	Maximum Continuous Operating Voltage Maximum r.m.s. voltage, which may be continuously applied to the SPD's mode of protection. — (IEC 61643-11)
I_n	Nominal Discharge Current Crest value of the current through the SPD having a current waveshape of 8/20. — (IEC 61643-11)
I_{PP}	Peak Pulse Current The peak pulse current applied to the TVS to determine the specific waveform of the clamping voltage VC. — (IEC 61643-321)
V_C	Clamping Voltage Peak voltage developed across the varistor terminations under standard atmospheric conditions, when passing an 8/20 μ s class current pulse.
C_V	Capacitance The capacitance measured at both ends of a transient suppression diode at a specific frequency and voltage. — (IEC 61643-321)
ATCO	Alloy Hot Fuse The temperature sensing element is a hot fuse made of alloy material.



注意

Usage

1. This product is suitable for 48V DC systems.
2. The voltage continuously applied to the thermal protected transient suppression diode should not exceed its maximum continuous operating voltage U_c .
3. The air pressure is 54 kPa to 106 kPa, corresponding to the altitude of +5000 m to -500 m.
4. Do not directly touch the body or pin when powered on to prevent electric shock.
5. Please do not use ketones, esters, benzenes, halogenated hydrocarbons and other polar solvents to clean this product, so as to avoid damaging the packaging layer of the product.

Replacement

TTVS is a non-repairable product. For safety sake, please use equivalent TTVS for replacement.

Storage

Do not store TTVS at high temperature, high humidity or corrosive gas environment. To avoid reducing the solderability of the pins, please use them up within 1 year after receiving the goods.

Installation Position

Do not install the TTVS on a place that may often suffer severe continuous vibration.

Mechanical Stress

Do not take violent action such as knocking when assembling to avoid mechanical damage.